

規 格 書 SPEAKER SPECIFICATION

客 戶 CUSTOMER'S NAME		承 認 審 核 製 作
名 稱 MODEL	客戶機種名稱 CUSTOMER'S NO. 本廠機種名稱 OUR MODEL NO. GC1009X (ROHS)	
1	口 徑 NOMINAL SIZE	68x106 mm. 2-1/2"x4" inch.
2	公稱阻抗 IMPEDANCE	25 Ω ± 15% at. 800 Hz. 1 V.
3	最低共振週波數 RESONANCE FO	240 Hz ± 48 Hz. FO Hz. 1 V.
4	出力音壓 S.P. LEVEL	1 w 50 cm average at 1K, 1.4K, 1.7K, 2K Hz
5	出力音壓週波數特性 RESPONSE	
6	交叉週波數 CROSSOVER FREQ.	MAX 10 dB Fo Hz ~ 10K Hz dB/OCT Net work
7	許容入力 INPUT POWER	定格入力 1 w. 最大入力 2 w. Nominal input Handling Capacity
8	動 作 OPERATION	Must be normal at program source 1 w.
9	聲音異常 BUZZ, RATTLE, ETC.	Must be normal at Since Wave 5 V.
10	磁束密度 FLUX DENSITY	Gauss ± 10%
11	總磁束 TOTAL FLUX	Max well min
12	磁 鐵 MAGNET	Size 12.5 x 3 mm gr oz
13	重 量 TOTAL WEIGHT	gr oz
14	連續負荷 LOAD TEST	After test meet Item 8 and 9 White noise 1 W. 24 Hours
15	失真率 DISTORTION	以 內 % MAX Hz 1 W.
16	耐熱性 HEAT TEST	After test meet Item 8 and 9 60±2 ±°C 20-50 %R. H 24 Hours
17	耐濕性 HUMIDITY TEST	After test meet Item 8 and 9 40±2 ±°C 90-95 %R. H 24 Hours

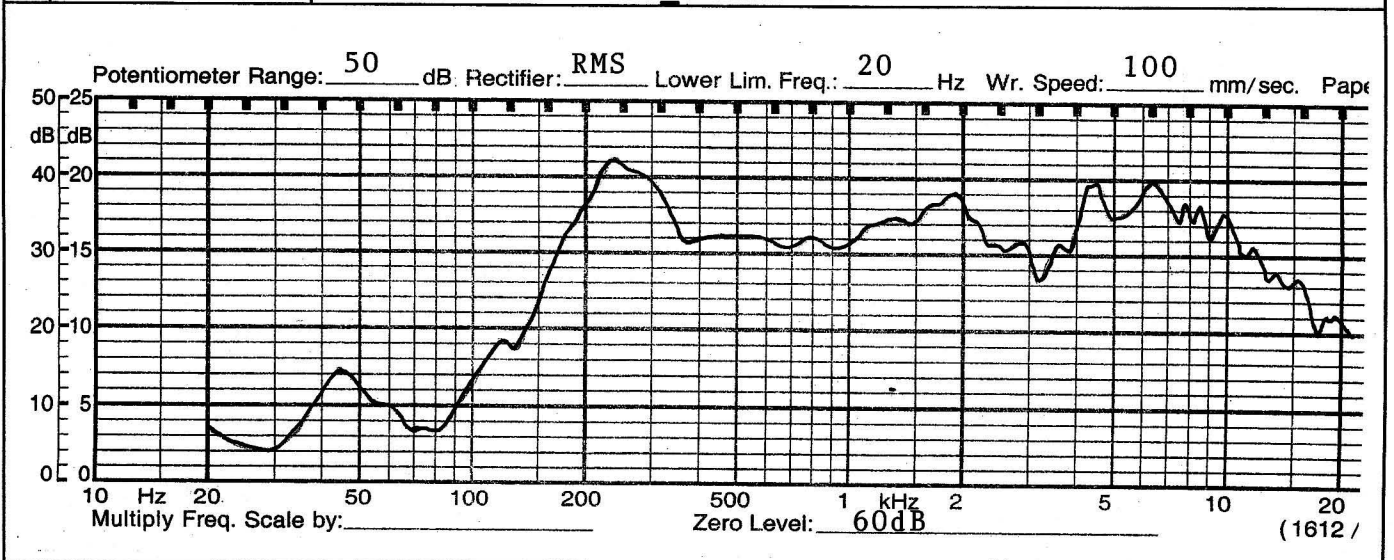

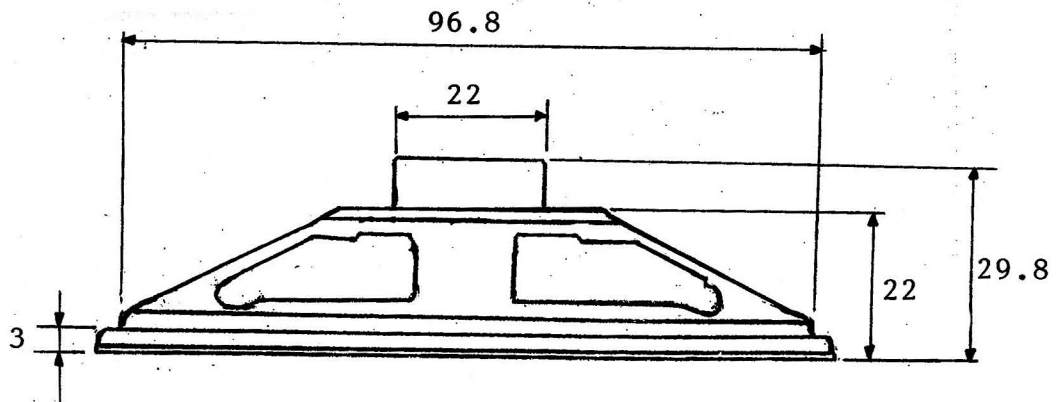
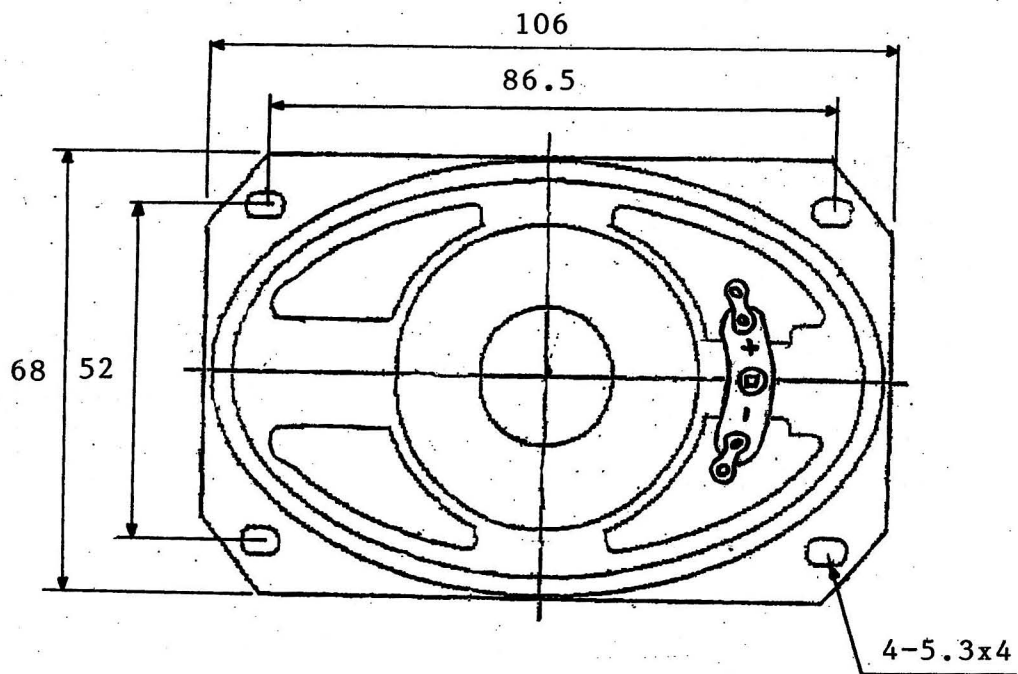

TOLERANCE: ± 0.5 M/M

APPROVED	CHECKED	DRAWING	CUSTOMER'S PART NO.
			AMAOTO'S PART NO. GC1009X

AMAOTO INDUSTRIAL CO., LTD.